

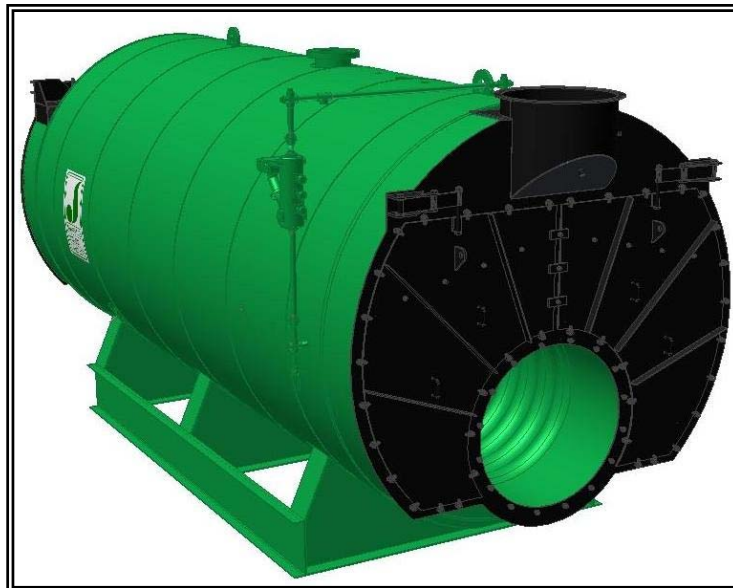

MODEL: PFTX 800-4

4-Pass Steam Packaged Firetube Boiler



Ratings & Performance Data

Horsepower 800							
Steam Storage, ft ³	158.7	Natural Gas Flow, SCFH (1,000 Btu/ft ³)**	32,211				
Steam Disengaging Area, ft ²	133.4	Combustion Air (15% Excess), SCFM***	5,894				
Total Heating Surface, ft ²	4,041	Flue Gas Flow Rate, lb/hr***	28,089				
Furnace Outside Diameter, in	49.5	Stack Flue Gas Velocity, ft/min***	2,355				
Furnace Heat Release Rate, Btu/ft ³ hr**	158,000	#2 Oil Flow, gal/hr (140,000 BTU/gal)**	221.7				
Total Combustion Volume, ft ³	267.5	#6 Oil Flow, gal/hr (150,000 BTU/gal)**	205.1				
Total Heat Release Rate, Btu/ft ³ hr**	120,000	Flue Gas Side Pressure Drop, in. H ₂ O	7.0				
Water Content N.W.L., gal	4,366	Water Content Flooded, gal.	5,553				
Approx. Dry Weight 15#, lb	53,500	Approx. Operating Weight 15#, lb.	89,800				
Approx. Dry Weight 150#, lb	58,000	Approx. Operating Weight 150#, lb.	94,300				
Approx. Dry Weight 200#, lb	62,100	Approx. Operating Weight 200#, lb.	98,400				
Approx. Dry Weight 250#, lb	65,400	Approx. Operating Weight 250#, lb.	101,700				
Approx. Dry Weight 300#, lb	70,500	Approx. Operating Weight 300#, lb.	106,800				
Performance Data							
Operating Pressure (psig)	Steam Rate (lb/hr)	Natural Gas		#2 Oil		#6 Oil	
		Stack Temp (F)	%Eff	Stack Temp (F)	%Eff	Stack Temp (F)	%Eff
10	27,783	273	85.6	280	88.7	286	89.5
50	27,244	330	84.1	338	87.3	345	88.0
100	26,953	370	83.1	378	86.3	385	87.0
150	26,790	398	82.4	406	85.6	413	86.3
200	26,689	420	81.9	428	85.0	436	85.8
250	26,624	438	81.4	446	84.6	454	85.3
300	26,582	454	81.0	462	84.2	470	84.9
*Based on 228°F feedwater and 3% O ₂ , ** Values calculated at 100 psi operating pressure, ***Calculated Firing Natural Gas							

Drawings - 4-Pass Steam Packaged Firetube Boiler

Connection & Opening Schedule			
Conn.	Description	Type	Qty
FW	Feedwater Inlet	2.00 FNPT	2
MS*	Main Steam	8.00 300# RF	1
CB	Continuous Blowoff	1.00 FNPT	1
BD	Blowdown Outlet	2.00 FNPT	2
MW	Manway	12 X 16	1
HH	Hand Hole	4 X 6	7
*12.00 150#RF Flange on 15 psig Design			

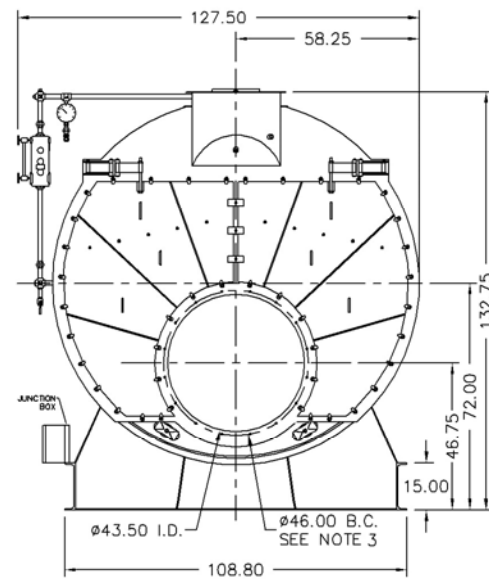

NOTE: (16) 5/8 UNC X 1.500 LONG STUDS EQUALLY SPACED STRADDLE CENTERLINES. STUDS FOR BURNER REFRACTORY (DRY OVEN) MOUNTING. REFRACTORY MUST EXTEND 20.00" MINIMUM PAST MOUNTING FLANGE.

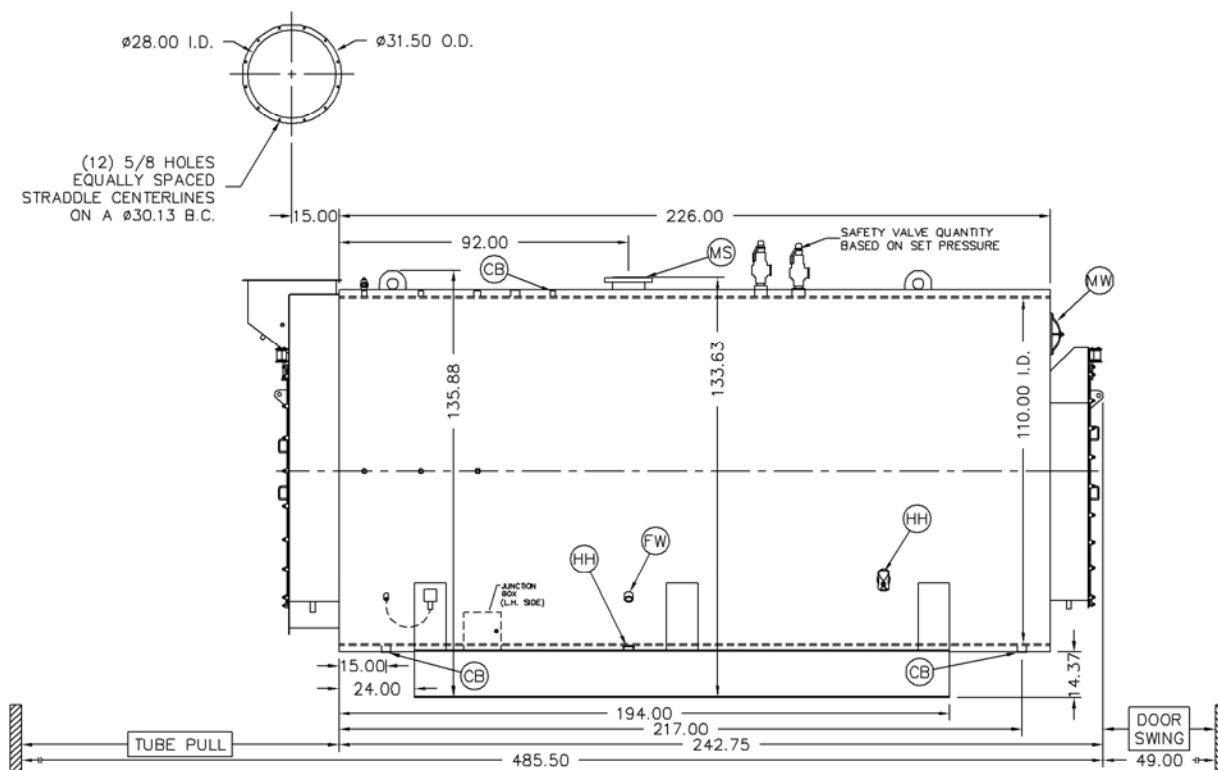

Notes:

150# Steam design shown, all dimensions given in inches.

Fuel piping and/or optional boiler trim may increase overall width.

Specifications subject to change to incorporate engineering advances.

MODEL: PFTX 800-4

Base Diagram

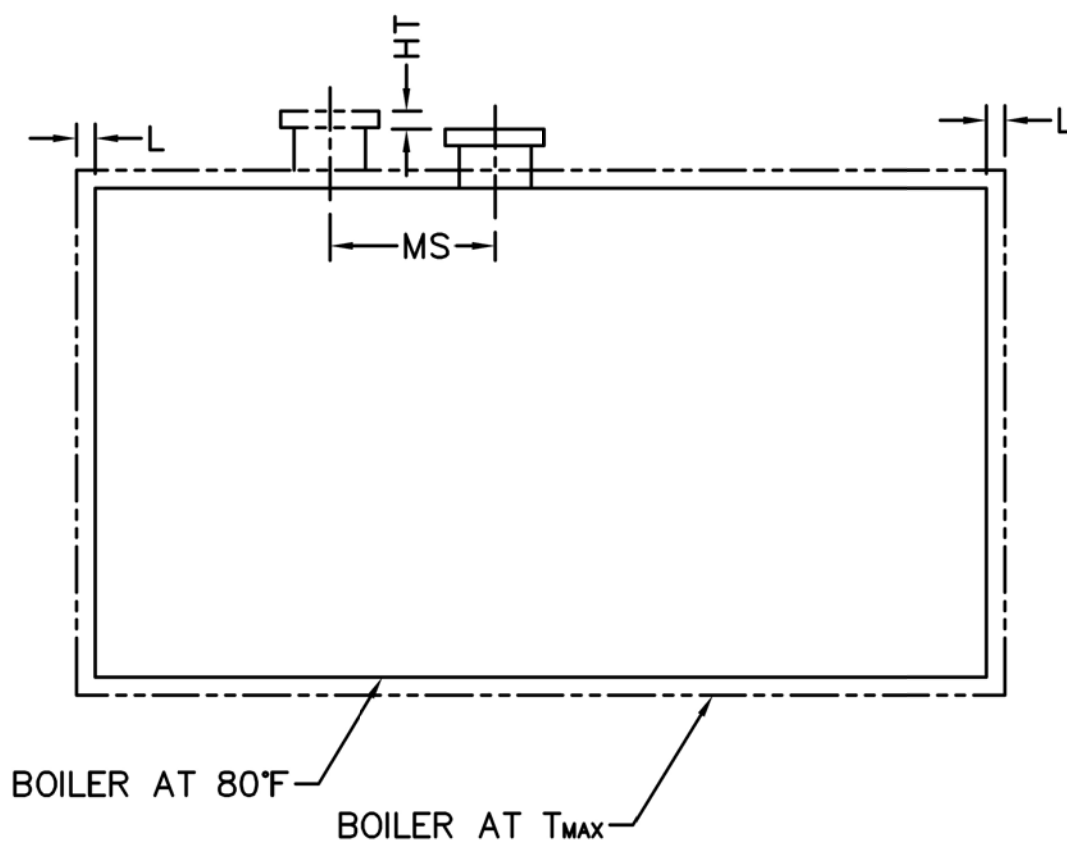
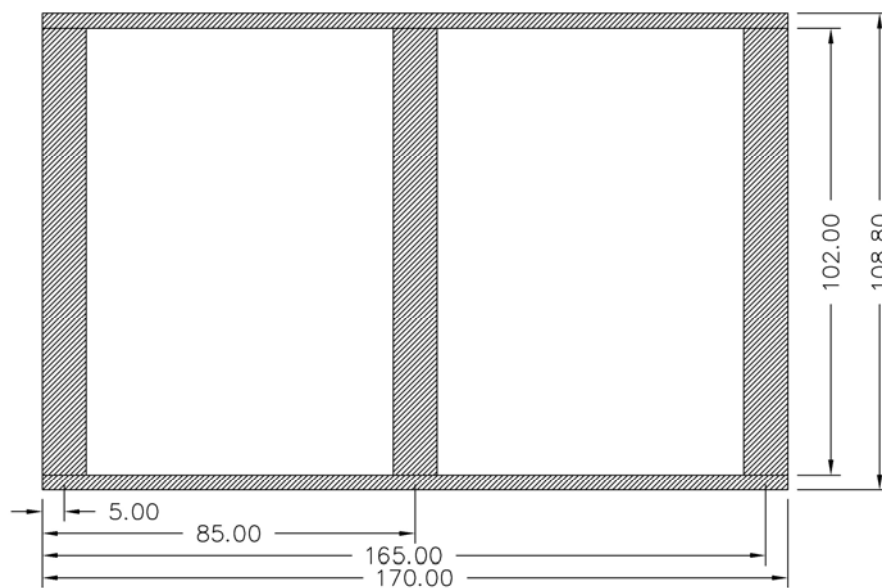

Thermal Expansion					
psig	15	150	200	250	300
Metal T_{MAX} (F)	240	366	388	406	421
L (in)	0.115	0.194	0.209	0.221	0.232
MS (in)	0.021	0.036	0.039	0.041	0.043
HT (in)	0.112	0.190	0.204	0.217	0.228

MODEL: PFTX 800-4

Nozzle Loadings

Maximum Allowable Load on Boiler Steam Nozzle					
	15# Design	150# Design	200# Design	250# Design	300# Design
F_{RRF} , lb	6,235	4,695	6,590	8,260	9,810
M_{RCM} , in-lb	50,040	58,795	83,195	109,040	142,075
M_{RLM} , in-lb	79,540	48,155	67,575	90,300	104,430

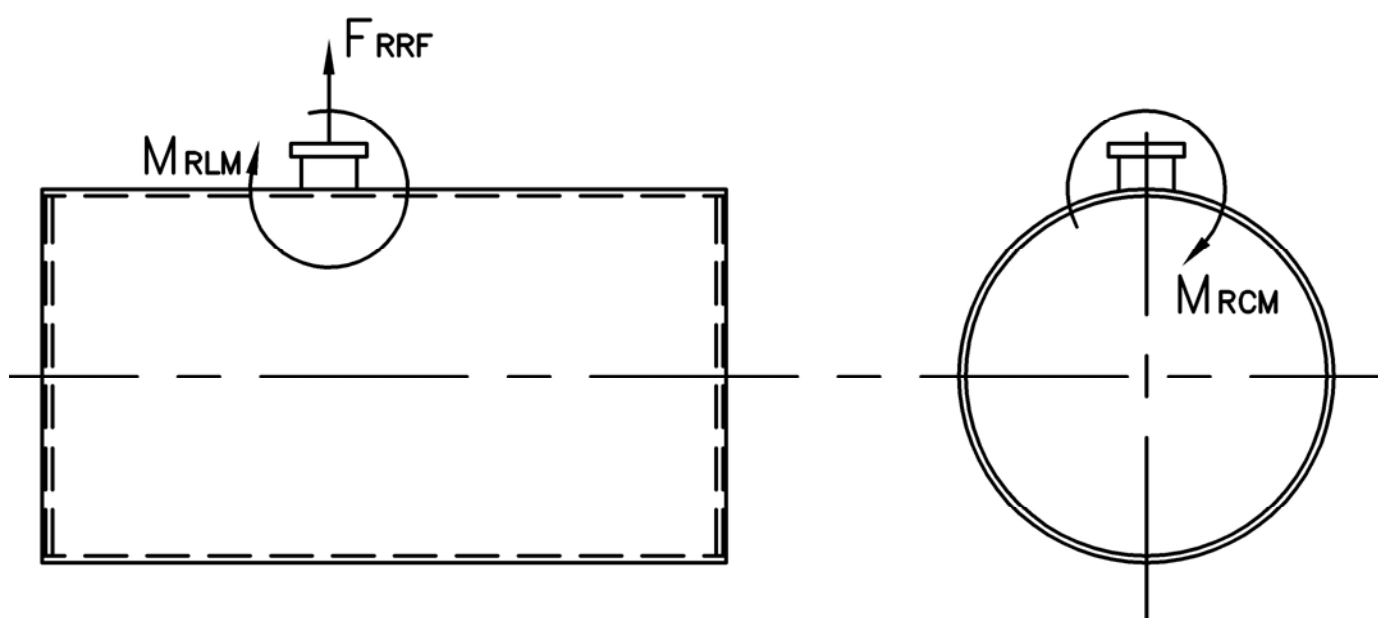

Distributed By:



300 Pine Street
P.O. Box 300
Ferrysburg, MI 49409-0300
Telephone: (616) 842-5050
Net: www.johnstonboiler.com