



MODEL: PFTX 2000-3

3-Pass Hot Water Packaged Firetube Boiler



Ratings & Performance Data

Horsepower 2000		Natural Gas Flow, SCFH (1,000 Btu/ft ³)**		78,185		
Total Heating Surface, ft ²	9,926	Combustion Air (15% Excess), SCFM***		14,307		
Furnace Outside Diameter, in	66.5	Flue Gas Flow Rate, lb/hr***		68,182		
Furnace Heat Release Rate, Btu/ft ³ hr**	179,000	Stack Flue Gas Velocity, ft/min***		1,845		
Total Combustion Volume, ft ³	627.9	#2 Oil Flow, gal/hr (140,000 Btu/gal)**		539.1		
Total Heat Release Rate, Btu/ft ³ hr**	125,000	#6 Oil Flow, gal/hr (150,000 Btu/gal)**		499.4		
Water Content Flooded, gal	11,188	Flue Gas Side Pressure Drop, in. H ₂ O		3.6		
Approx. Dry Weight 30#, lb	107,200	Approx. Operating Weight 30#, lb		202,400		
Approx. Dry Weight 60#, lb	112,000	Approx. Operating Weight 60#, lb		207,200		
Approx. Dry Weight 125#, lb	116,500	Approx. Operating Weight 125#, lb		211,700		
Performance Data						
Operating Temperature (F)	Natural Gas		#2 Oil		#6 Oil	
	Stack Temp (F)	%Eff	Stack Temp	%Eff	Stack Temp (F)	%Eff
180	243	86.1	256	89.2	265	89.8
200	263	85.6	275	88.7	284	89.4
220	282	85.2	294	88.3	303	88.9
240	301	84.7	313	87.8	322	88.5
*Based on 20°F difference in supply/return, ** Values calculated at 200°F operating temperature, ***Calculated Firing Natural Gas						

Drawings - 3-Pass Hot Water Packaged Firetube Boiler

Connection & Opening Schedule			
Conn.	Description	Type	Qty
FW	Feedwater Inlet	2.50 FNPT	2
WS	Water Supply	16.00 150#RF	1
WR	Water Return	16.00 150#RF	1
DO	Drain Outlet	2.00 FNPT	2
MW	Manway	12 X 16	1
HH	Hand Hole	4 X 6	7
Supply and return outlets ASME flanged drilling			

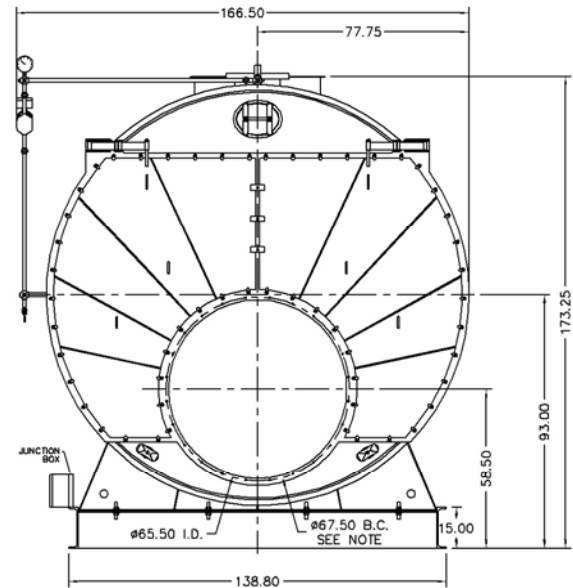

NOTE: (24) 5/8 UNC X 1.500 LONG STUDS EQUALLY SPACED STRADDLE CENTERLINES. STUDS FOR BURNER REFRACTOR (DRY OVEN) MOUNTING. REFRACTOR MUST EXTEND 22.25" MINIMUM PAST MOUNTING FLANGE.

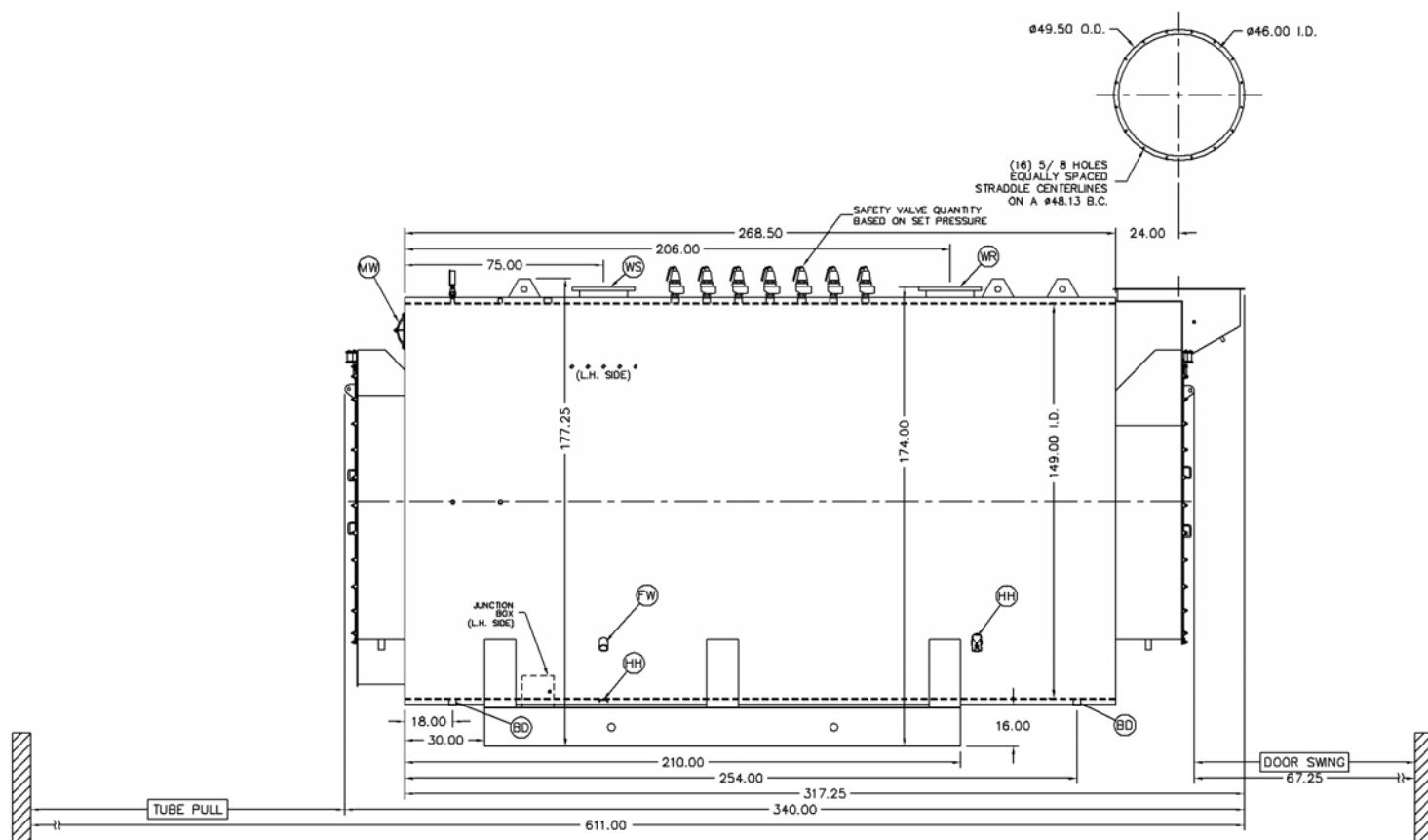

Notes:
30# Hot Water design shown, all dimensions given in inches.
Fuel piping and/or optional boiler trim may increase overall width.
Specifications subject to change to incorporate engineering advances.

MODEL: PFTX 2000-3

Base Diagram

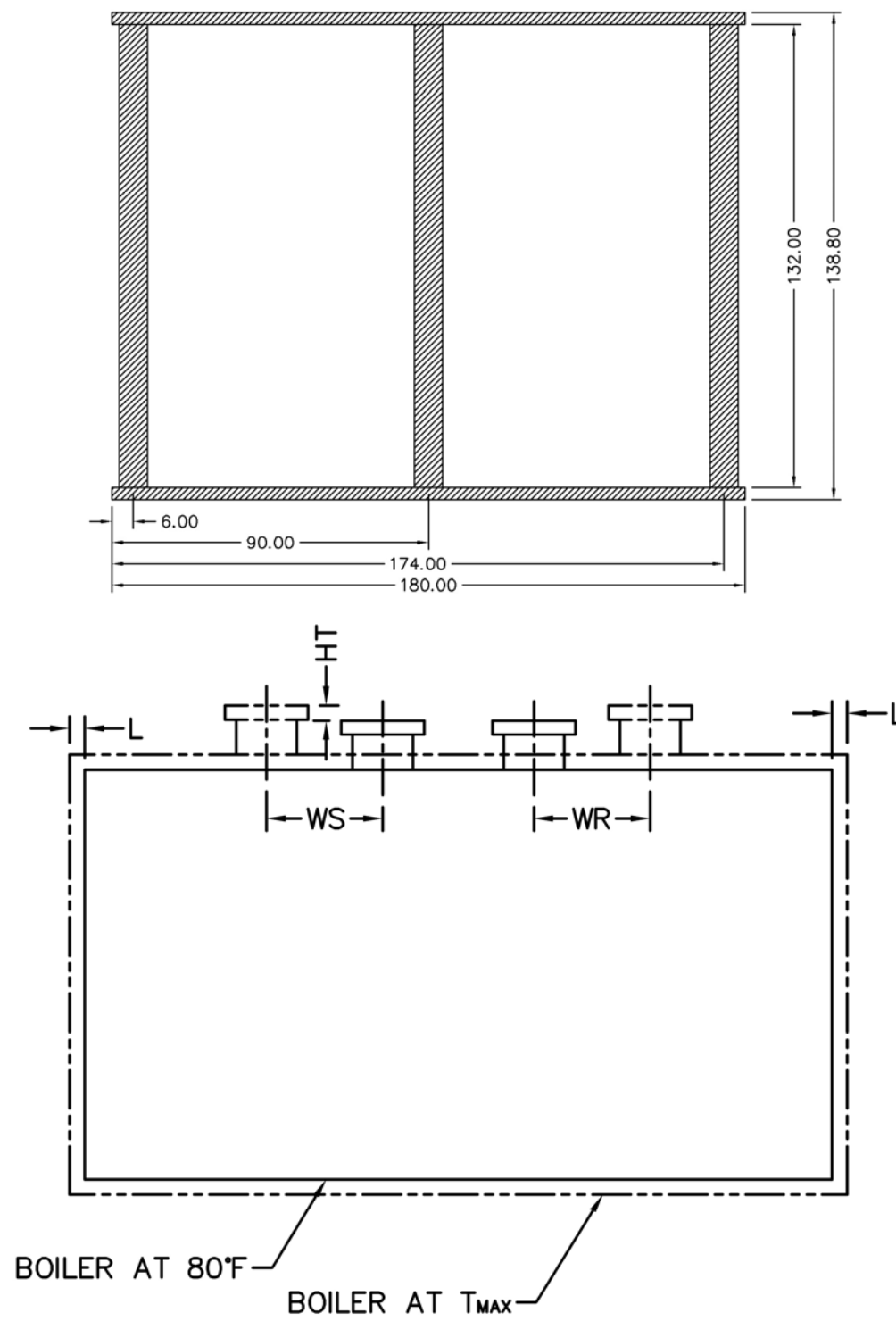

Thermal Expansion				
Metal T _{MAX} (F)	180	200	220	240
L (in)	0.081	0.097	0.113	0.129
WS (in)	0.011	0.013	0.015	0.017
WR (in)	0.068	0.081	0.095	0.108
HT (in)	0.090	0.108	0.126	0.144

MODEL: PFTX 2000-3

Nozzle Loadings

Maximum Allowable Load on Outlet & Return Nozzles				
	30# Design	60# Design	125# Design	160# Design
FRRF, lb	6,570	4,400	11,495	24,695
MRCM, in-lb	73,145	73,145	252,720	352,760
MRLM, in-lb	104,275	69,825	208,555	451,605

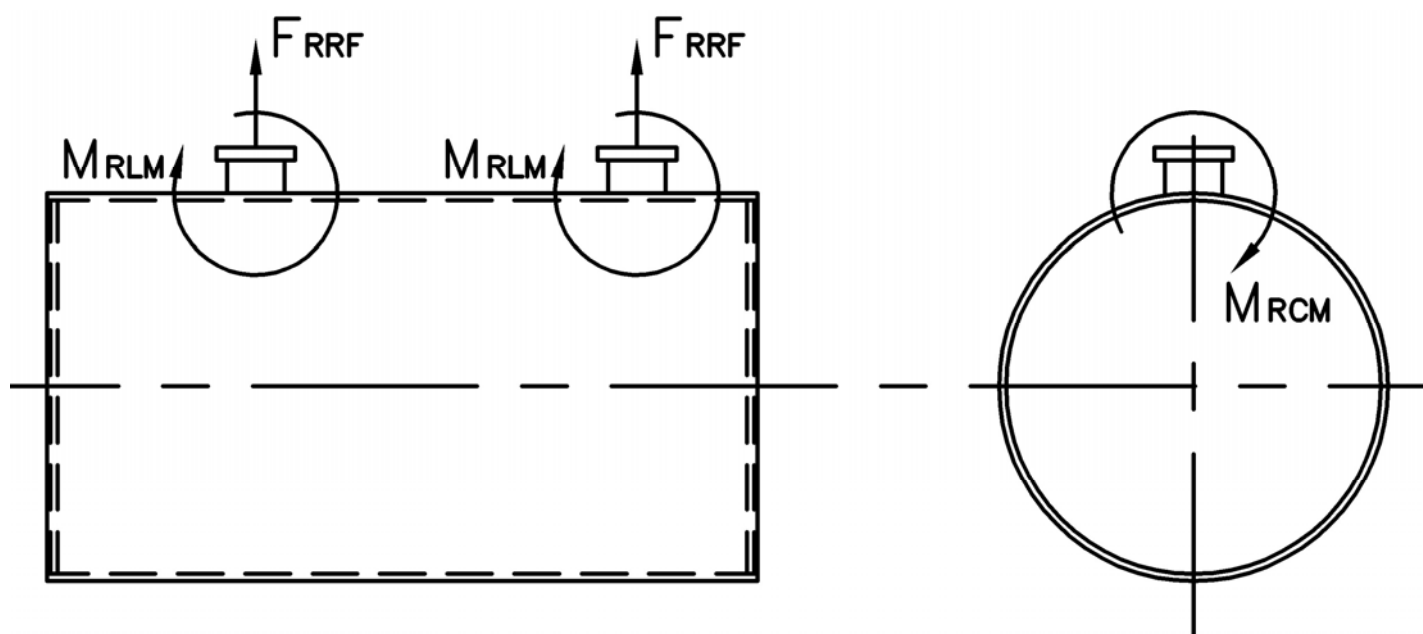

Distributed By:



300 Pine Street
P.O. Box 300
Ferrysburg, MI 49409-0300
Telephone: (616) 842-5050
Net: www.johnstonboiler.com