

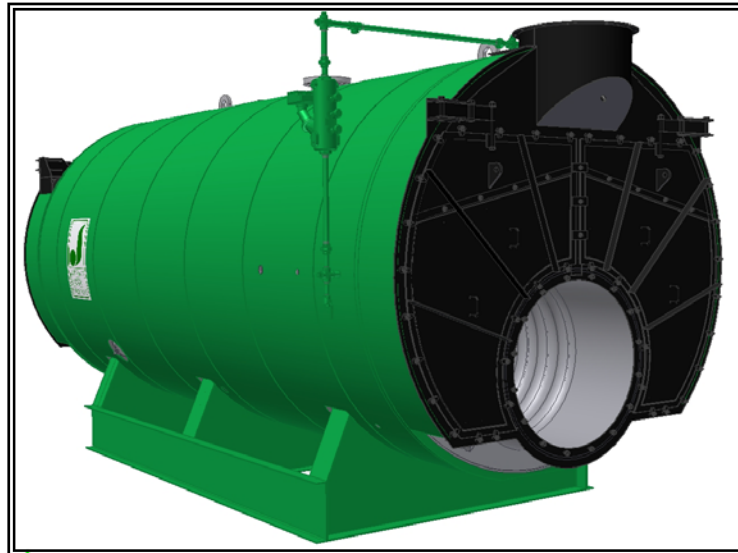

## MODEL: PFTX 50/80-4

### 4-Pass Steam Packaged Firetube Boiler



### Ratings & Performance Data

Horsepower 50-80					
Steam Storage, ft <sup>3</sup>	20.2				
Steam Disengaging Area, ft <sup>2</sup>	32.7	Natural Gas Flow, SCFH (1,000 Btu/ft <sup>3</sup> )**	3,266		
Total Heating Surface, ft <sup>2</sup>	399	Combustion Air (15% Excess), SCFM***	598		
Furnace Outside Diameter, in	24.0	Flue Gas Flow Rate, lb/hr***	2,850		
Furnace Heat Release Rate, Btu/ft <sup>3</sup> hr**	171,000	Stack Flue Gas Velocity, ft/min***	1,360		
Total Combustion Volume, ft <sup>3</sup>	32.2	#2 Oil Flow, gal/hr (140,000 Btu/gal)**	22.5		
Total Heat Release Rate, Btu/ft <sup>3</sup> hr**	101,000	Flue Gas Side Pressure Drop, in. H <sub>2</sub> O	3.0		
Water Content N.W.L., gal	619	Water Content Flooded, gal	770		
Approx. Dry Weight 15#, lb	10,000	Approx. Operating Weight 15#, lb	15,300		
Approx. Dry Weight 150#, lb	10,300	Approx. Operating Weight 150#, lb	15,600		
Approx. Dry Weight 200#, lb	10,900	Approx. Operating Weight 200#, lb	16,200		
Approx. Dry Weight 250#, lb	11,400	Approx. Operating Weight 250#, lb	16,700		
Approx. Dry Weight 300#, lb	12,000	Approx. Operating Weight 300#, lb	17,300		
Performance Data*					
Operating Pressure (psig)	Steam Rate (lb/hr)	Natural Gas		#2 Oil	
		Stack Temp (F)	%Eff	Stack Temp (F)	%Eff
10	2,778	294	84.7	303	87.8
50	2,724	351	83.1	360	86.2
100	2,695	391	82.0	400	85.1
150	2,679	419	81.2	428	84.3
200	2,669	441	80.6	450	83.7
250	2,662	459	80.1	468	83.2
300	2,658	475	79.7	484	82.8
Calculations based on 80 horsepower design					
*Based on 228°F feedwater and 3% O <sub>2</sub> , ** Values calculated at 100 psi operating pressure, ***Calculated Firing Natural Gas					

Connection & Opening Schedule			
Conn.	Description	Type	Qty
FW	Feedwater Inlet	1.00 FNPT	2
MS*	Main Steam	4.00 300# RF	1
CB	Continuous Blowoff	1.00 FNPT	1
BD	Blowdown Outlet	1.50 FNPT	2
MW	Manway	12 X 16	1
HH	Hand Hole	4 X 6	6

\*8.00 150#RF Flange on 15 psig Design

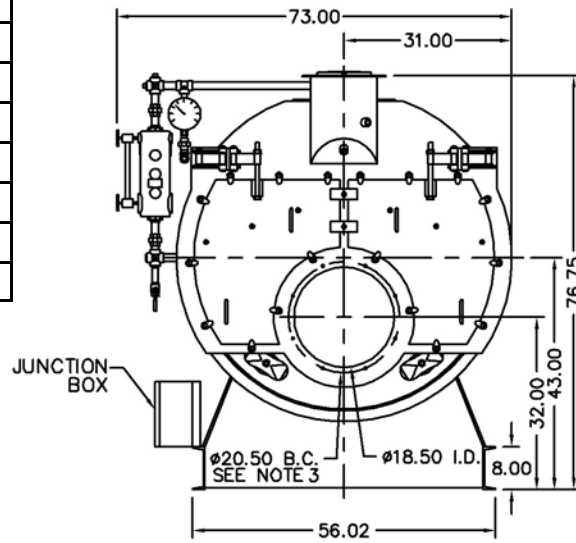

NOTE: (8) 1/2 UNC X 1.375 LONG STUDS EQUALLY SPACED STRADDLE CENTERLINES. STUDS FOR BURNER REFRACTORY (DRY OVEN) MOUNTING. REFRACTORY MUST EXTEND 11.25" MINIMUM PAST MOUNTING FLANGE.

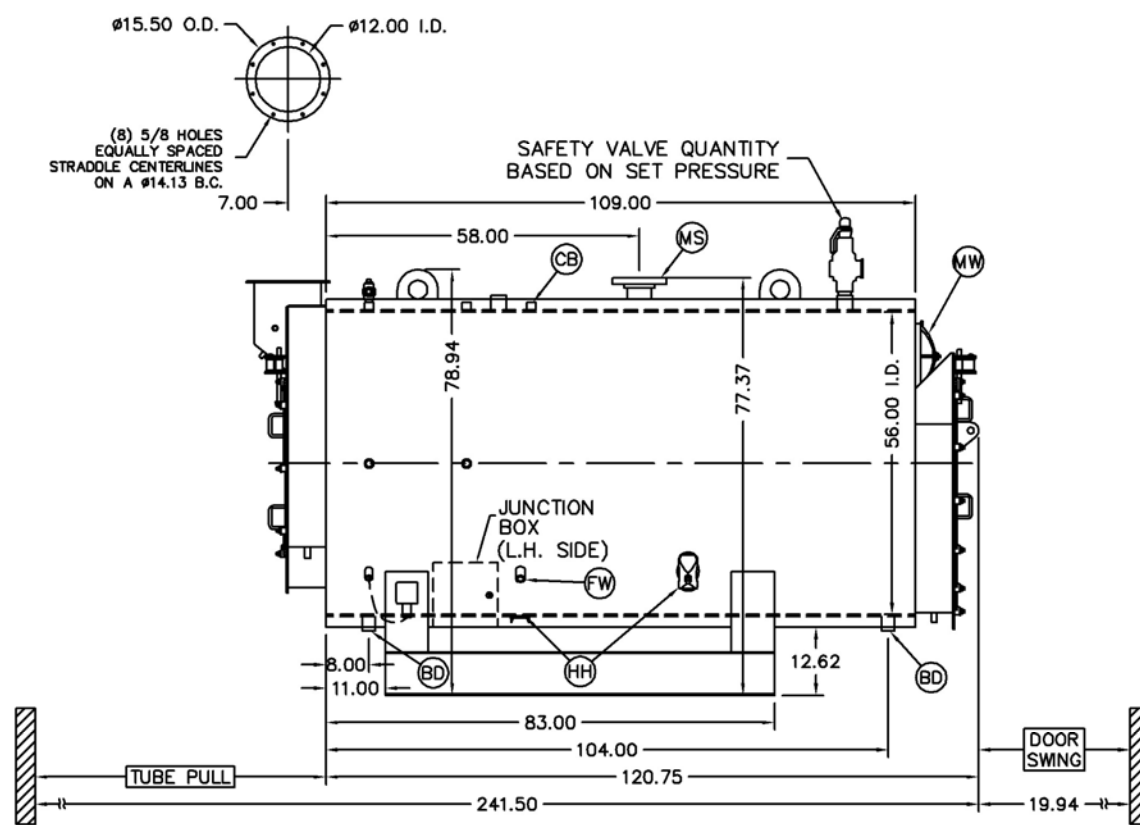

Notes:  
 150# Steam design shown, all dimensions given in inches.  
 Fuel piping and/or optional boiler trim may increase overall width.  
 Specifications subject to change to incorporate engineering advances.

# MODEL: PFTX 50/80-4

## Base Diagram

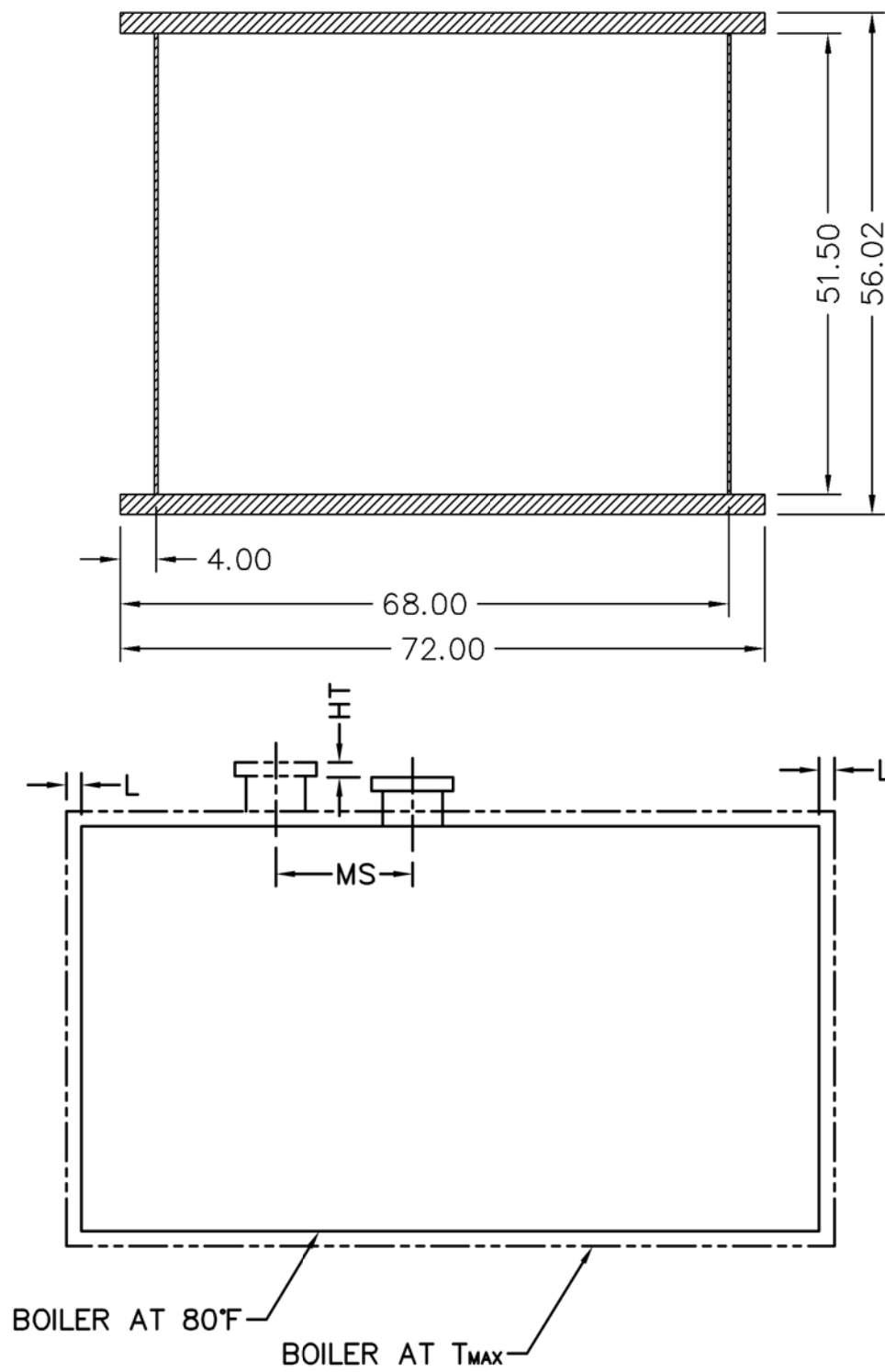

Thermal Expansion					
psig	15	150	200	250	300
Metal T <sub>MAX</sub> (F)	240	366	388	406	421
L (in)	0.055	0.093	0.101	0.107	0.112
MS (in)	0.004	0.006	0.006	0.007	0.007
HT (in)	0.057	0.097	0.104	0.111	0.116

# MODEL: PFTX 50/80-4

## Nozzle Loadings

Maximum Allowable Load on Boiler Steam Nozzle					
	15# Design	150# Design	200# Design	250# Design	300# Design
$F_{RRF}$ , lb	4,785	1,705	1,705	2,140	2,870
$M_{RCM}$ , in-lb	19,895	9,194	9,190	15,390	18,035
$M_{RLM}$ , in-lb	36,145	8,540	8,540	11,875	15,510

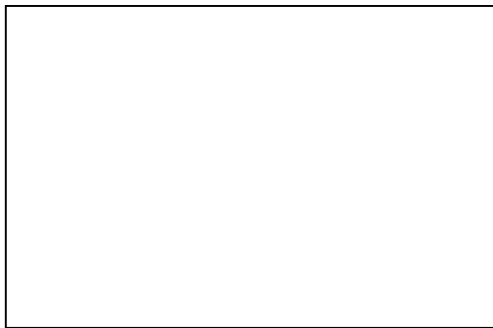
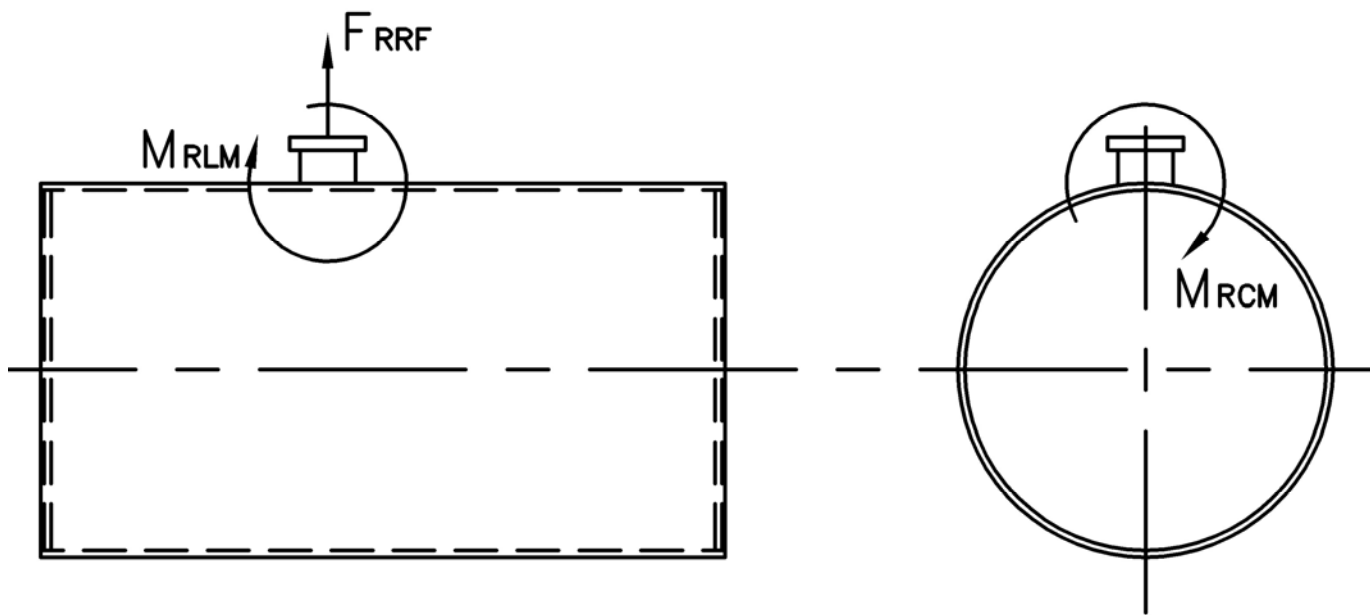

300 Pine Street  
P.O. Box 300  
Ferrysburg, MI 49409-0300  
Telephone: (616) 842-5050  
Net: [www.johnstonboiler.com](http://www.johnstonboiler.com)