



MODEL: PFTS 2000-3

3-Pass Steam Packaged Firetube Boiler



Ratings & Performance Data

Horsepower 2000							
Steam Storage, ft ³	230.1	Natural Gas Flow, SCFH (1,000 Btu/ft ³)**		80,770			
Steam Disengaging Area, ft ²	191.7	Combustion Air (15% Excess), SCFM***		14,780			
Total Heating Surface, ft ²	9,926	Flue Gas Flow Rate, lb/hr***		70,435			
Furnace Outside Diameter, in	66.5	Stack Flue Gas Velocity, ft/min***		2,254			
Furnace Heat Release Rate, Btu/ft ³ hr**	185,000	#2 Oil Flow, gal/hr (140,000 BTU/gal)**		556.3			
Total Combustion Volume, ft ³	627.9	#6 Oil Flow, gal/hr (150,000 BTU/gal)**		514.9			
Total Heat Release Rate, Btu/ft ³ hr**	129,000	Flue Gas Side Pressure Drop, in. H ₂ O		3.6			
Water Content N.W.L., gal	9,467	Water Content Flooded, gal.		11,188			
Approx. Dry Weight 15#, lb	107,200	Approx. Operating Weight 15#, lb.		187,500			
Approx. Dry Weight 150#, lb	128,100	Approx. Operating Weight 150#, lb.		208,400			
Approx. Dry Weight 200#, lb	141,700	Approx. Operating Weight 200#, lb.		222,000			
Approx. Dry Weight 250#, lb	151,500	Approx. Operating Weight 250#, lb.		231,800			
Approx. Dry Weight 300#, lb	157,000	Approx. Operating Weight 300#, lb.		237,300			
Performance Data							
Operating Pressure (psig)	Steam Rate (lb/hr)	Natural Gas		#2 Oil		#6 Oil	
		Stack Temp (F)	%Eff	Stack Temp (F)	%Eff	Stack Temp (F)	%Eff
10	69,457	300	85.1	312	88.2	321	88.9
50	68,110	356	83.8	368	86.9	376	87.6
100	67,381	395	82.9	406	86.0	415	86.7
150	66,975	422	82.3	433	85.3	441	86.1
200	66,722	443	81.8	454	84.8	462	85.6
250	66,559	461	81.3	472	84.4	480	85.2
300	66,456	476	81.0	487	84.0	495	84.8
*Based on 228°F feedwater and 3% O ₂ , ** Values calculated at 100 psi operating pressure, ***Calculated Firing Natural Gas							

Drawings - 3-Pass Steam Packaged Firetube Boiler

Connection & Opening Schedule			
Conn.	Description	Type	Qty
FW	Feedwater Inlet	2.50 FNPT	2
MS*	Main Steam	14.00 300# RF	1
CB	Continuous Blowoff	1.00 FNPT	1
BD	Blowdown Outlet	2.00 FNPT	2
MW	Manway	12 X 16	1
HH	Hand Hole	4 X 6	7
*28.00 150#RF Flange on 15 psig Design			

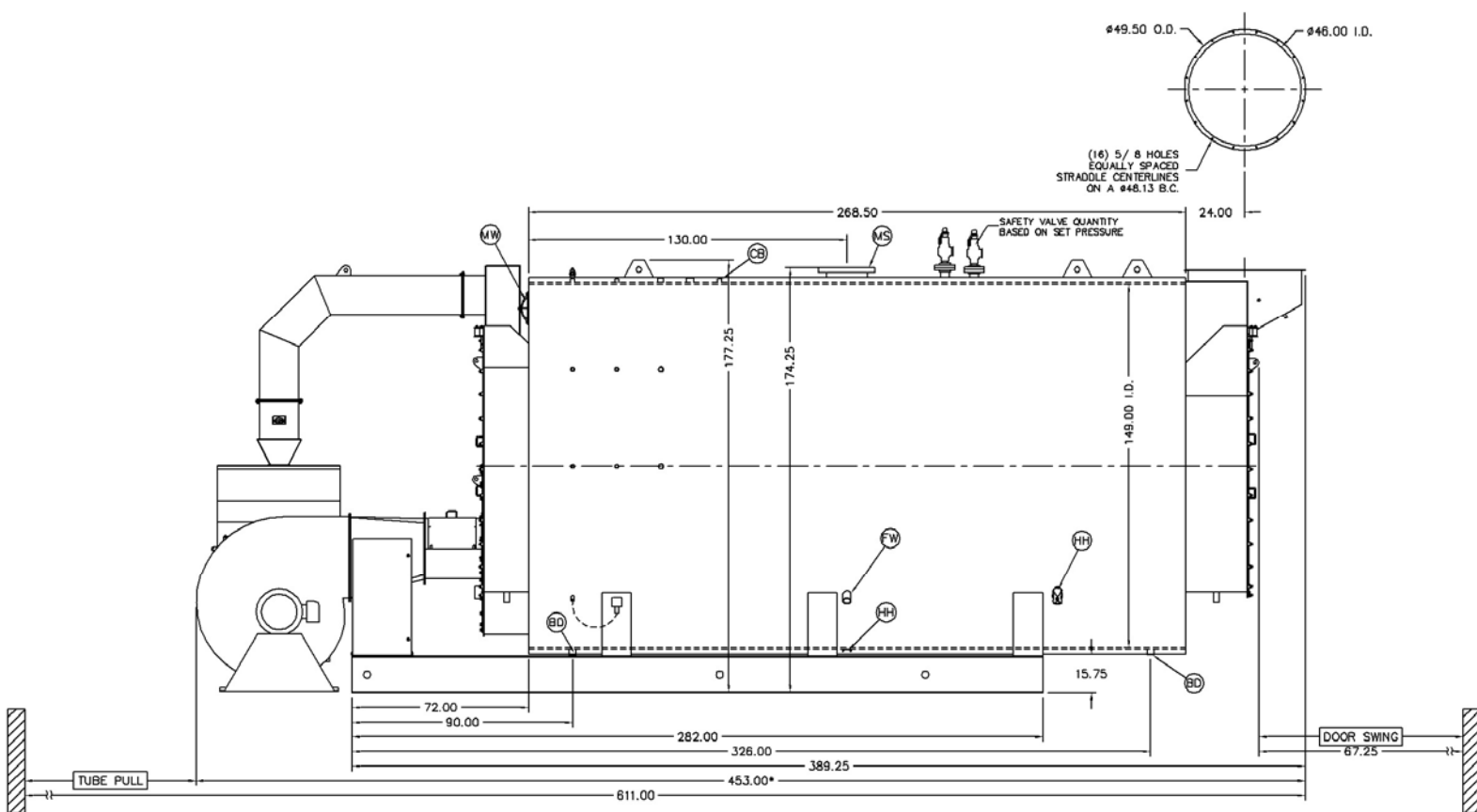
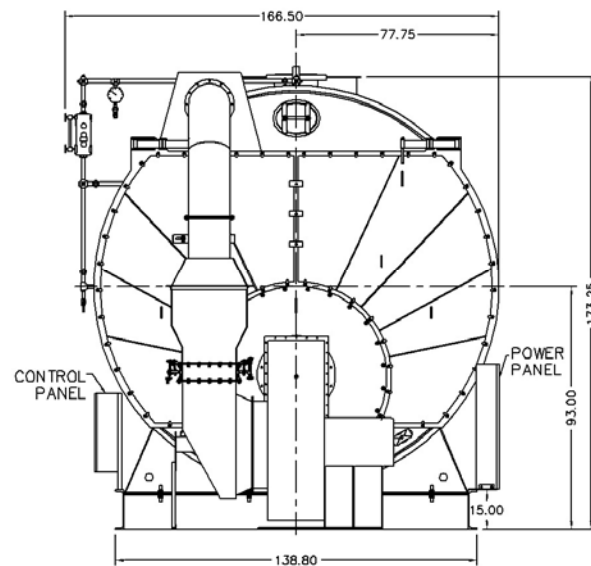

Notes:

- 150# Steam design shown, all dimensions given in inches.
- Fuel piping and/or optional boiler trim may increase overall width.
- Specifications subject to change to incorporate engineering advances.
- *May vary on low-NO_x designs

MODEL: PFTS 2000-3

Base Diagram

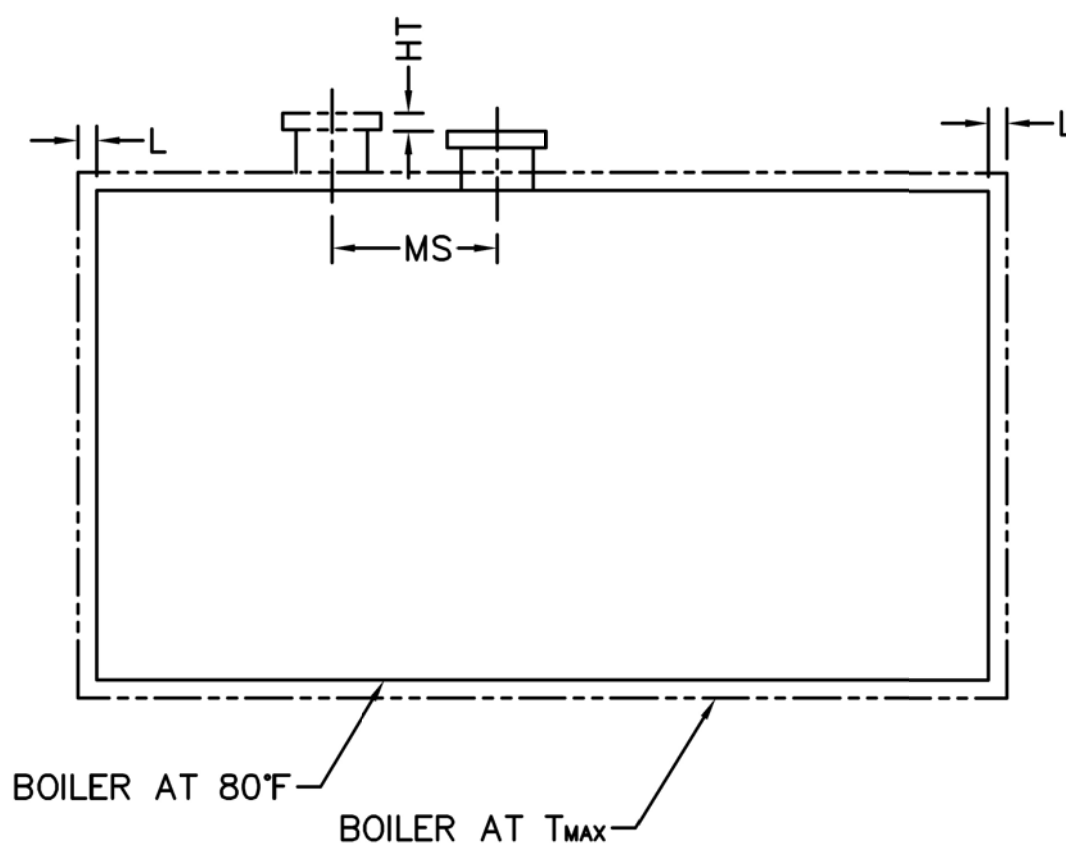
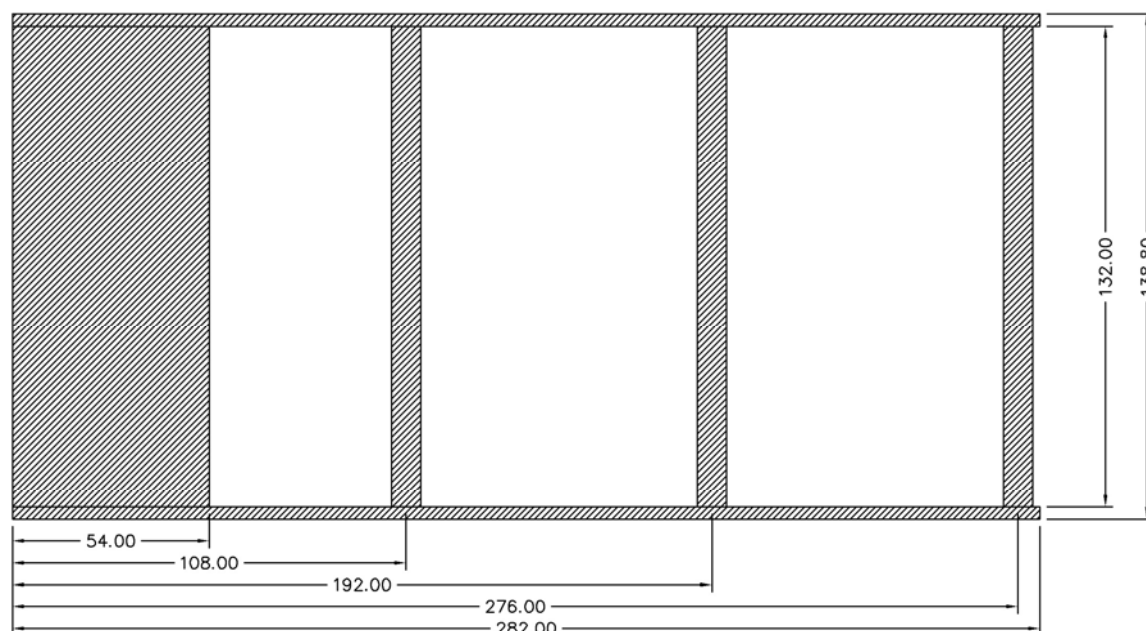

Thermal Expansion					
psig	15	150	200	250	300
Metal T_{MAX} (F)	250	366	388	406	422
L (in)	0.137	0.230	0.248	0.263	0.275
MS (in)	0.038	0.063	0.068	0.072	0.076
HT (in)	0.153	0.257	0.277	0.293	0.307

MODEL: PFTS 2000-3

Nozzle Loadings

Maximum Allowable Load on Boiler Steam Nozzle			
	15# Design	150# Design	200# Design
F_{RRF} , lb	16,935	7,140	11,515
M_{RCM} , in-lb	198,005	140,857	233,345
M_{RLM} , in-lb	433,555	112,160	169,885

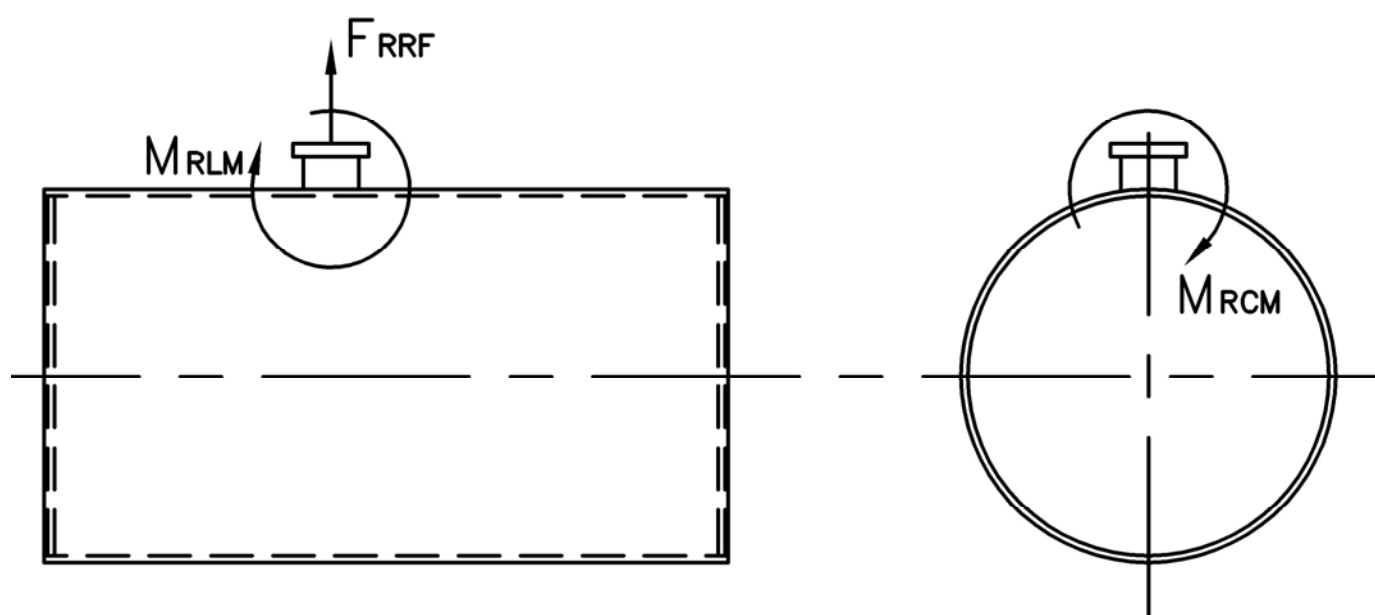

Distributed By:



300 Pine Street
P.O. Box 300
Ferrysburg, MI 49409-0300
Telephone: (616) 842-5050
Net: www.johnstonboiler.com

Stack Emissions-Natural Gas (1,000 Btu/CF)				
	PPMv (Corr to 3% O ₂)	lb/MBtu	lb/hr @ Full Rate	Ton/Yr @ Full Rate
NO _x *	110	0.131	10.577	46.327
	30	0.036	2.885	12.635
	9	0.011	0.865	3.790
CO	50	0.037	2.97	12.997
CO ₂	2.55 lb/lb fuel	119.76	9,673	42,368
H ₂ O	2.03 lb/lb fuel	106.16	8,575	37,556
Stack Emissions-#2 Oil** (140,000 Btu/gal)				
NO _x	128	0.174	13.560	59.394
CO	50	0.037	2.861	12.533
CO ₂	3.20 lb/lb fuel	168.53	13,126	57,492
H ₂ O	1.12 lb/lb fuel	71.20	5,545	24,289

* 110 ppm "A" Burner, 30 ppm A-FGR Burner, 9 ppm FIR Burner
**0.02% fuel bound Nitrogen