

CONNECTION SCHEDULE

CONN.	DESCRIPTION	SIZE	TYPE
A	FEEDWATER INLET	2.00	FNPT
B	AUX. FEEDWATER INLET	2.00	FNPT
C	FLUE OUTLET	32.00	ID
D	MAIN STEAM OUTLET	10.00	300#RF
F	CONTINUOUS BLOWOFF OUTLET	1.00	FNPT
G	SAFETY VALVE OUTLET	2.50	FNPT
H	BLOWDOWN OUTLET	2.00	FNPT
I	MAIN GAS INLET	3.00	FNPT
J	MAIN GAS VENT VALVE OUTLET	1.50	FNPT
L	PILOT GAS VENT VALVE OUTLET	0.38	FNPT

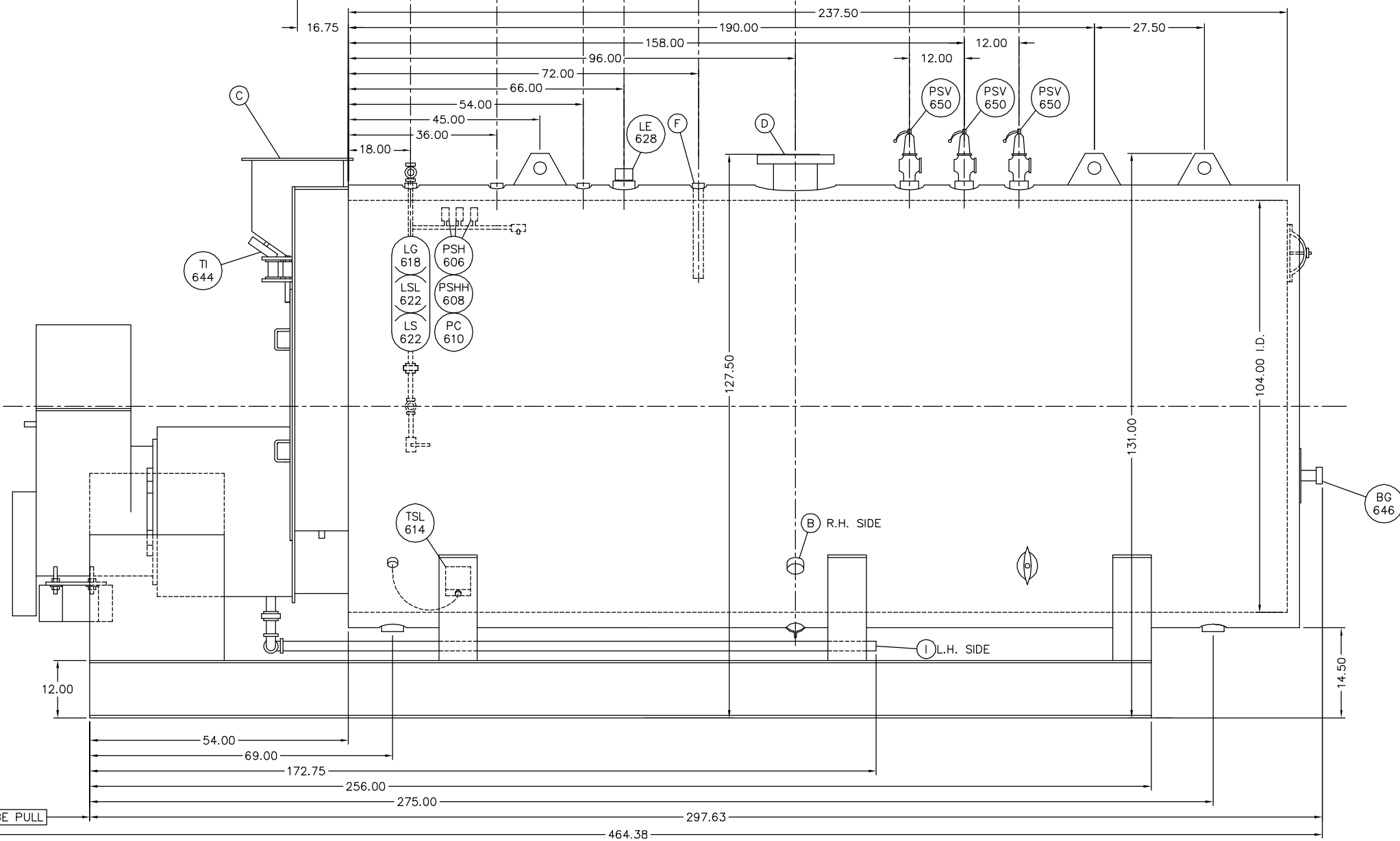
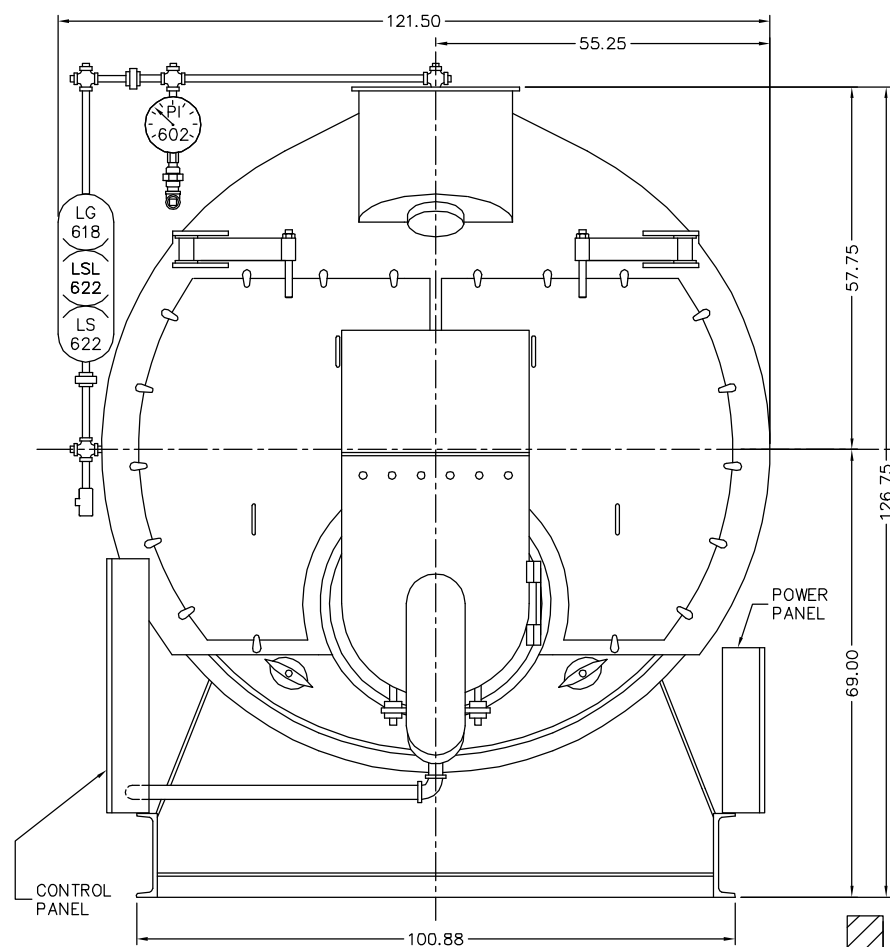
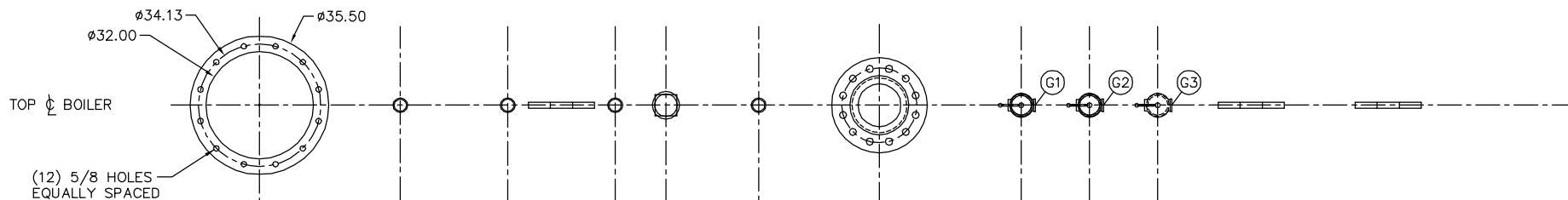

NOTES: THIS DRAWING IS FOR DIMENSIONAL DATA ONLY. SEE PIPING & INSTRUMENT DRAWINGS FOR ACTUAL TRIM & INSTRUMENTATION PROVIDED. ALL DIMENSIONS IN INCHES UNLESS OTHERWISE NOTED. MINIMUM BOILER SIDE & REAR AISLE CLEARANCE: 36.00. ELECTRICAL PANEL LOCATIONS SHOWN ARE APPROXIMATE; CONSULT FACTORY IF PLACEMENT IS CRITICAL. REFER TO NATIONAL ELECTRICAL CODE (NFPA-70) FOR REQUIRED WORKING CLEARANCE ABOUT PANELS; CONSULT LOCAL CODES WHICH MAY SUPERCEDE THESE REQUIREMENTS. BOILER COMPLETELY COVERED WITH 2" INSULATION & NONCORRODING STEEL JACKET.

DWG NO. 300B0416-01	REVISIONS A 4-24-12 MN	FLUE OUTLET WAS 26.00. UPDATED RELATED DIMENSIONS. MAIN STEAM WAS 8.00. REARRANGED TO CURRENT PV STANDARD. LENGTH W/ TUBE PULL WAS 461.38.	 <p>THIS DRAWING IS THE PROPERTY OF THE JOHNSTON BOILER COMPANY. THE DISCLOSURES CONTAINED ON THIS DRAWING ARE MADE WITH THE UNDERSTANDING THAT THEY ARE CONFIDENTIAL AND WILL NOT BE USED IN ANY WAY DETRIMENTAL TO THIS COMPANY'S INTEREST.</p>	SCALE NONE	<p>JOHNSTON BOILER COMPANY</p> <p>FERRYSBURG, MICHIGAN 49409</p>	SO#
DATE 3-5-03	DRAWN JRS	CHECKED		APPROVED		DWG. No. 300B0416-01
			DIMENSIONAL DIAGRAM - XID		PFXA700/900-2G150S	