

MODEL: PFTX 250-4

Nozzle Loadings

Maximum Allowable Load on Outlet & Return Nozzles				
	30# Design	60# Design	125# Design	160# Design
F_{RRF} , lb	4,385	3,620	2,460	4,110
M_{RCM} , in-lb	21,710	21,710	22,115	37,415
M_{RLM} , in-lb	29,900	24,700	17,095	30,105

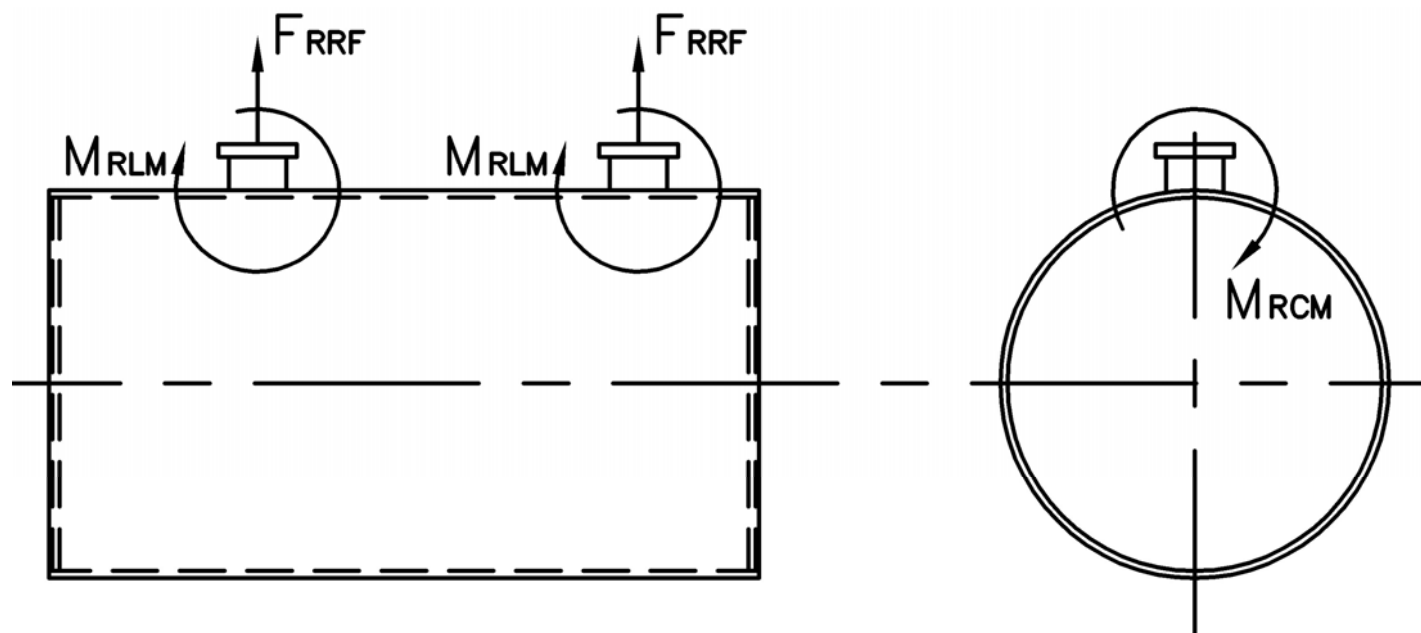

Distributed By:



300 Pine Street
P.O. Box 300
Ferrysburg, MI 49409-0300
Telephone: (616) 842-5050
Net: www.johnstonboiler.com

MODEL: PFTX 250-4

4-Pass Hot Water Packaged Firetube Boiler

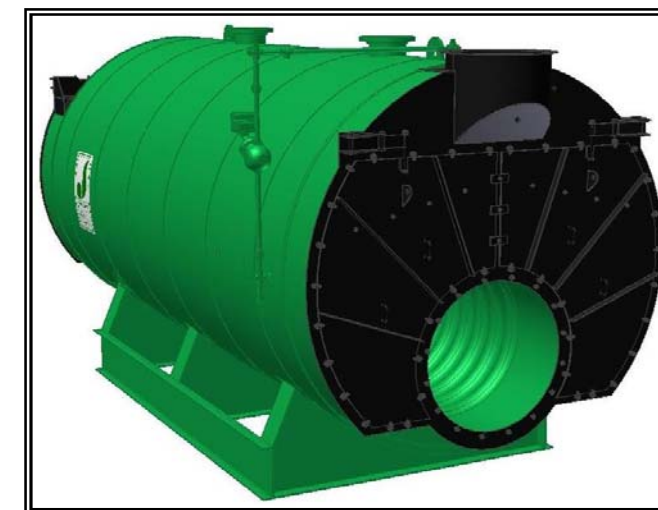

Ratings & Performance Data

Horsepower 250		Natural Gas Flow, SCFH (1,000 Btu/ft ³)**	9,814
Total Heating Surface, ft ²	1,295	Combustion Air (15% Excess), SCFM***	1,796
Furnace Outside Diameter, in	40.5	Flue Gas Flow Rate, lb/hr***	8,559
Furnace Heat Release Rate, Btu/ft ³ hr**	157,000	Stack Flue Gas Velocity, ft/min***	1,548
Total Combustion Volume, ft ³	97.4	#2 Oil Flow, gal/hr (140,000 Btu/gal)**	67.7
Total Heat Release Rate, Btu/ft ³ hr**	101,000	#6 Oil Flow, gal/hr (150,000 Btu/gal)**	62.7
Water Content Flooded, gal	1,988	Flue Gas Side Pressure Drop, in. H ₂ O	3.0
Approx. Dry Weight 30#, lb	21,200	Approx. Operating Weight 30#, lb	36,200
Approx. Dry Weight 60#, lb	21,300	Approx. Operating Weight 60#, lb	36,300
Approx. Dry Weight 125#, lb	22,000	Approx. Operating Weight 125#, lb	37,000

Operating Temperature (F)	Natural Gas		#2 Oil		#6 Oil	
	Stack Temp (F)	%Eff	Stack Temp (F)	%Eff	Stack Temp (F)	%Eff
180	261	85.8	275	88.8	283	89.5
200	280	85.3	294	88.3	303	89.0
220	300	84.8	314	87.8	323	88.5
240	319	84.3	333	87.3	343	88.0

*Based on 20°F difference in supply/return, ** Values calculated at 200°F operating temperature, ***Calculated Firing Natural Gas

Connection & Opening Schedule			
Conn.	Description	Type	Qty
FW	Feedwater Inlet	1.50 FNPT	2
WS	Water Supply	6.00 150#RF	1
WR	Water Return	6.00 150#RF	1
DO	Drain Outlet	2.00 FNPT	2
MW	Manway	12 X 16	1
HH	Hand Hole	4 X 6	6
Supply and return outlets ASME flanged drilling			

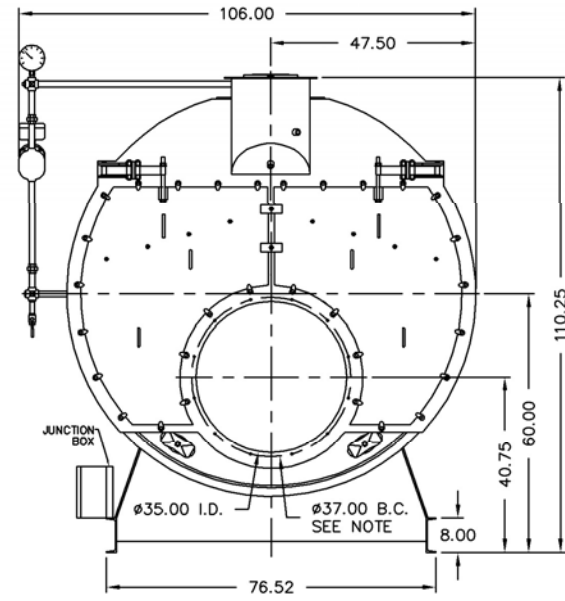

NOTE: (12) 1/2 UNC X 1.375 LONG STUDS EQUALLY SPACED STRADDLE CENTERLINES. STUDS FOR BURNER REFRACTORY (DRY OVEN) MOUNTING. REFRACTORY MUST EXTEND 14.50" MINIMUM PAST MOUNTING FLANGE.

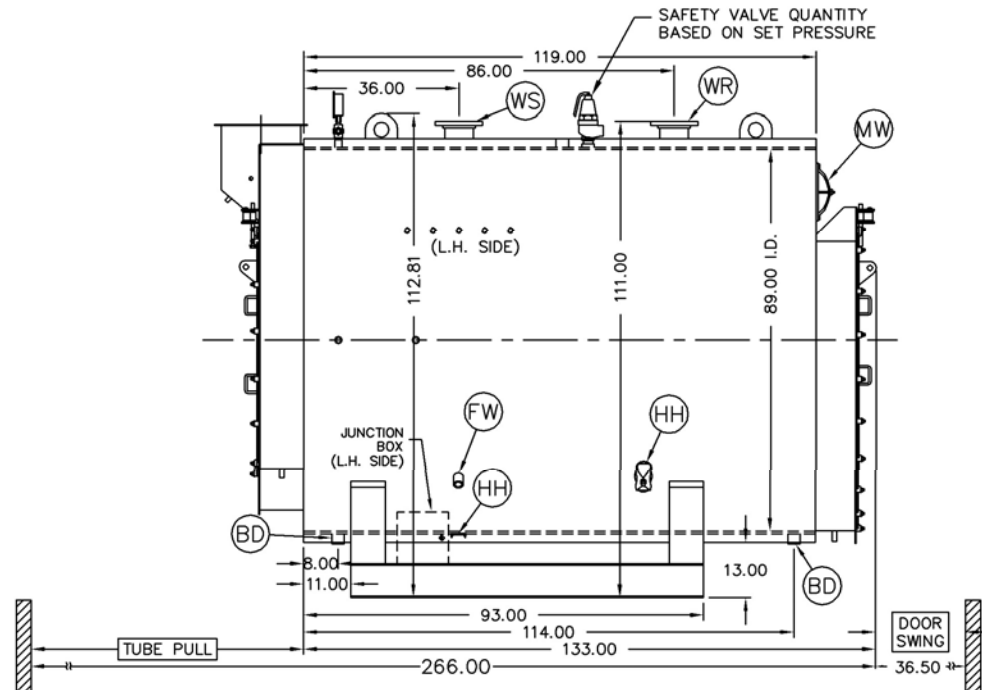
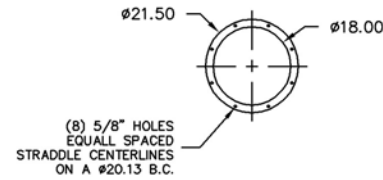

Notes:
 30# Hot Water design shown, all dimensions given in inches.
 Fuel piping and/or optional boiler trim may increase overall width.
 Specifications subject to change to incorporate engineering advances.

Base Diagram

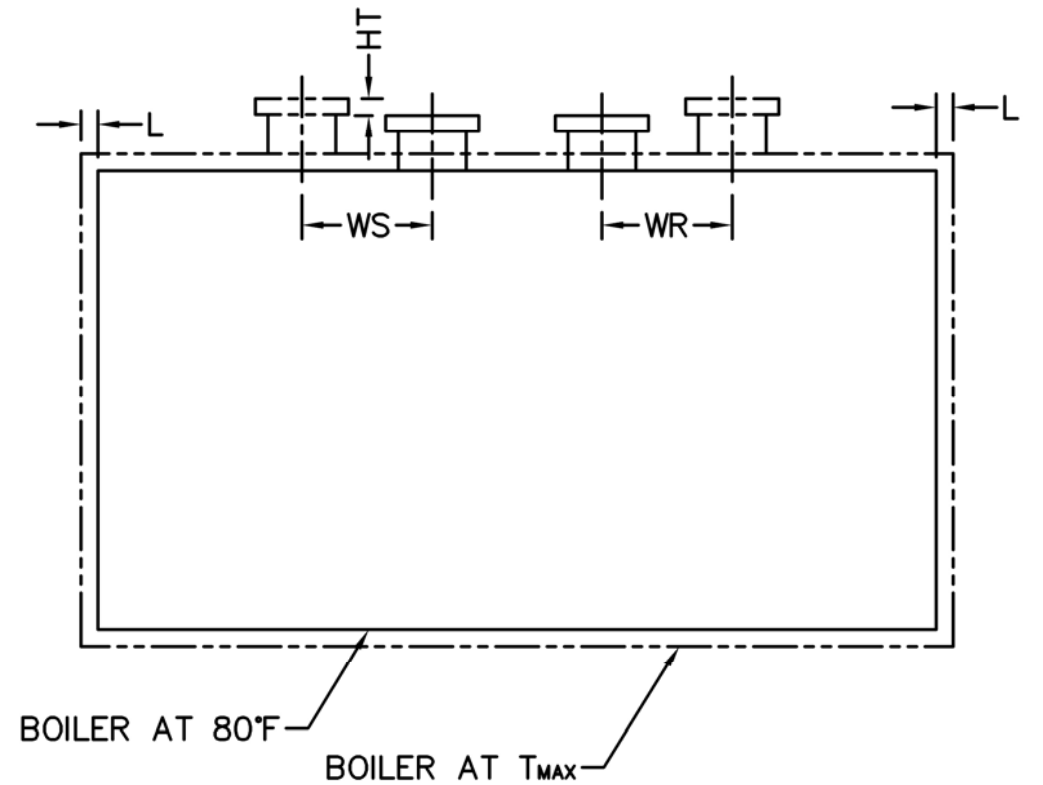
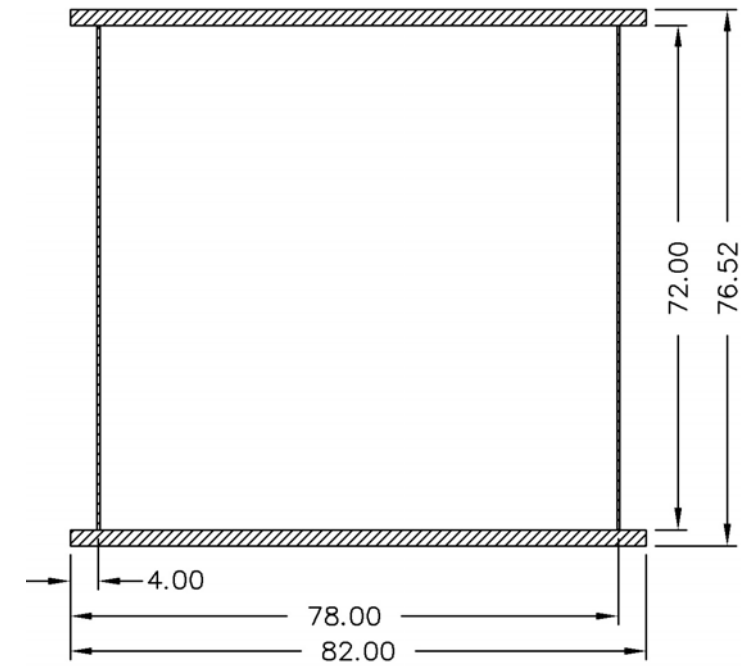

Thermal Expansion				
Metal T _{MAX} (F)	180	200	220	240
L (in)	0.036	0.043	0.050	0.057
WS (in)	0.014	0.017	0.020	0.023
WR (in)	0.016	0.019	0.022	0.025
HT (in)	0.054	0.064	0.075	0.086